

Table of Contents

Lines from the Commodore:	1
Membership Notice:	2
New Member Award:	2
Support Youth Sailing:	4
Trip Tales:	5
Sunfish Sailing:	6
Let's Go Sailing:	7
R/C Sailing Fleet:	8
Beginning Sailing:	8
Sewing Seeds at Jacobsen Park:	9
Youth Sailing Needs Your Help:	10
2024 Sailing Retrospective:	11-14
That's My Boat (Dave Leddy):	15-16
That's My Boat (Jim & Nicole Moan):	17-19
First Splash Regatta:	20
2025 ASA Certification Courses:	21
The Librarian's Bookshelf:	22
CRSA Cookbook:	23
2025 Race Calendar:	23
Guess the Sailor:	24
Classified Ads:	25
MainSHEET and CRSA Info:	26

Lines from the Commodore

Snow and cold temperatures! I can't wait until warmer weather and the start of the sailing season. A Cave Run Sailing group has just returned from the Caribbean. They picked a good time to go. Back to reality with so much coming up:

- Feb. 27th: Trip Tales, USVI
- April 9th: Newcomer's social
- April 15th: First Sunfish Tuesday evening sail
- April 19th: First Splash Regatta at Jacobson Park
- April 22nd: Beginning Sailing Class

We are off to a great start with another fun-filled year of sailing and socializing planned. Come participate and volunteer to help.

Graeme Wilson
Commodore CRSA



Sailing Boats Returning to Yabase, Lake Biwa, Utagawa Hiroshige Japanese, ca. 1835, Source: The Met Collection (Open Access Image), <https://www.metmuseum.org/art/collection/>

Membership Notice

It's that time of year! Time to register as a new member or renew your membership with the Cave Run Sailing Association.

All annual dues are assessed on January 1st and the payment deadline is April 1st to renew your active membership. It's easy! Just follow one of these procedures.

If you are requesting membership as a new member, go to our website at caverunsailing.org. At the top right, click 'Join Us' which will take you to a 'New Members Registration' form. Create your new account and then you will be directed to pay the dues with a credit or debit card.

If you are an active member, go to the caverunsailing.org website, log in, and then click on 'My Account'. Then select 'My Membership' and choose 'Renew or Change Membership'. You will be directed to your payment method to finalize the transaction.

We like to monitor the membership roster so please renew at your earliest convenience. We look forward to your participation in this upcoming year's events and programs.

Thanks,
Fred Pfister, Membership Chairman

New Member Award

Our most active new member is Tracy Burton. Tracy couldn't be at the Annual Awards Banquet and missed the November 2024 issue of *The MainSHEET*. Congratulations, Tracy!



Tracy Burton - Most Active New Member award

NAUTICAL ACCOUTREMENTS

- ★ REAL SEABAGS
CANVAS & LEATHER
4 SIZES
- ★ SALTY COASTER
SETS
BASIC AND DELUXE
- ★ BELT KNIFE
SHEATHS
- ★ LEATHER EYE
PATCHES
LEFT OR RIGHT
- ★ WEAR LEATHER
FOR DOCK LINES
AND SAILS
- ★ SHIP'S LOGS
FINE LEATHER WITH
SHIP NAME
AND DECOR
- ★ CAPTAIN'S
DELUX BELTS
- ★ BRASS AND
STAINLESS STEEL
HARDWARE
UTILITY GRADE —
NOT FOR RIGGING
OR CLIMBING
- ★ FIREARM CASES

**CALL
(859) 293-2793**

DESIGN AND GRAPHICS BY CLAIRE LAWTON



2025 Youth Sailing Benefit Regatta
Saturday, May 17

<https://www.caverunsailing.org/benefit-ys-regatta/>

SUPPORT THE CRSA YOUTH SAILING ACADEMY

Donate & Sponsor

\$10000 Fleet Admiral

- Name our Catalina 22 sailboat (5yrs)
- Free admission to club events (5yrs)
- PLUS Admiral & Commodore benefits!

\$5000 Admiral

- Pick 1 of 3 club regattas to lead sponsor
- Complimentary entry to all events (1 yr)
- PLUS Commodore benefits!

\$1000 Commodore

- Place your name on one Sunfish (1 yr)
- Name on the committee boat banner
- Recognition at Captain's meeting banner
- On-line promotion on *caverunsailing.org* (1 yr)

\$500 Captain

\$400 1st Mate

\$300 2nd Mate

\$200 3rd Mate

\$100 Boatswain

\$50 Steward

\$25 Deckhand



Support Youth Sailing

The Cave Run Sailing Association needs help in soliciting funds from individuals and businesses for the Cave Run Youth Sailing Academy (CRYSA).



CAVE RUN
YOUTH SAILING ACADEMY

Donation categories include: Providing sailing instructions (Jacobson Park, Lexington) and learning materials to youth (\$35 per student); paying the rental use fee for the Pavillion (\$115); providing lunch on regatta day (\$250); providing funds for the luncheon on Pirates Day, the highlight of the Sailing Camp (\$750); helping buy used Sunfish Sailboats (\$1500); assisting with trailer repair (\$150); purchasing Sunfish sails \$300); and buying more used Prams (\$3000).

Donations can also be made for the categories listed below (all donors will be recognized by category in our newsletter):

- a. \$25 Deck Hand donation
- b. \$50 Steward donation
- c. \$100 Bosun donation
- d. \$200 Third Mate donation
- e. \$300 Second Mate donation
- f. \$400 First Mate donation
- g. \$500 Captain donation
- h. \$1000 Commodore donation: Place your name on one of the Sunfish used at both Jacobson Park (Lexington) and Cave Run Lake for at least 1 year. Your company banner will be displayed on the side of the committee boat as well as the site for all meals at all 3 CRSA regattas (First Splash Sunfish Regatta, 4/19/25 at Jacobson Park; Youth Sailing Benefit Regatta, 5/17/2025; Cave Run Lake Grand Annual Regatta, 10/4,5/2025 at Cave Run Lake). Space for one person on the committee boat or on a sailboat in the race.
- i. \$5000 Admiral donation: Brand your business in a big way as lead sponsor for any of the clubs 3 regattas (___First Splash Sunfish Regatta, 4/19/25 at Jacobson Park; ___Youth Sailing Benefit Regatta, 5/17/2025; ___Grand Annual Regatta, 10/4,5/2025 at Cave Run Lake). Use the entire year for promotions on all our online and in person locations. Recieve two free admissions to all events, including the Annual Meeting, for the entire 2025 year. Receive all items listed under the Commodore donation.
- j. \$10,000 Fleet Admiral donation: Embrace the huge opportunity to name for five years the Catalina 22 sailboat located at Cave Run Lake. Receive free admission to all club events for five years. Receive all items listed under the Admiral and Commodore donations.

Please help us identify possible businesses with contact names. Contact Len Boral at lboral00@yahoo.com or 859-779-5842.

To donate, go to the CRSA website at CaveRunSailing.org. Click the 'Donate' button and follow the prompts.



2 Youth 0 Sailing 2 Benefit Regatta 5 Saturday, May 17

**SUPPORT THE CRSA
YOUTH SAILING ACADEMY**

CRSYA is growing!

Historically, 20-25 youth, ages 7- 17 enroll in July CRSY Youth Sailing Camp, held at Jacobson Park, Lexington, KY.

2024 was our best year yet. Lets TOP IT!

CRSYA depends on volunteers and equipment donations to keep youth camp accessible and registration fees low.

Why Youth Sailing?

Sailing Develops:

- Ⓡ Teamwork
- Ⓡ Communication
- Ⓡ Problem Solving
- Ⓡ Responsibility
- Ⓡ Environmental Stewardship
- Ⓡ Technical Skills



Cave Run Sailing Association is a strong, vibrant sailing & social association representing 150 families and 450 individuals. We are regionally based in Lexington/Fayette County with members throughout the Bluegrass and as far as Lebanon Junction to Charleston, WV.

Ⓡ Approximately 15 - 20+ boats and 60+ individuals participate annually in the **Youth Sailing Benefit Regatta.**

Ⓡ Meet at West Group, at Twin Knobs Campground, Morehead KY

Ⓡ Box lunches provided on Race Day.

Anticipated Schedule

- 9:30am** – Registration
- 10:00am** – Skippers Meeting
- 11:30am** – Races Begin
- 2:30pm** – Awards

<https://www.caverunsailing.org/>



Trip Tales

Join us for Trip Tales at 5:30 on Thursday, Feb 27!

The event will be held at our favorite venue, the home of Liz Harris in Lexington!

Please RSVP to Liz.Harris.consulting@gmail.com. The address will be sent to you when you RSVP.

Please bring your favorite beverage and an appetizer or dish to share.



Sunfish Sailing

As these thoughts become words we are experiencing negative temperatures and there is snow over palm trees in the Gulf States. January is often a great time for planning, so enjoy this snow now, but think about upcoming April 15th and 19th when we'll again be putting Sunfish in the water. Weather is unpredictable, but rest assured that we will be checking the water and air temperature. We will also have a chase boat at the ready.



Don't be disheartened by the cold and drear. Spring is will soon arrive. It is coming quickly and hopefully like a lion this year. As it approaches, dust off your gear, shed your winter-induced loafing, and grab your thirst for excitement and the adventure of sailing. Remember, the advantages of sailing in the springtime include better winds (much puffier than the summer doldrums), water that is sometimes cleaner with a higher oxygen content, a verdant green dotting the hills, new life springing forth, and so much more.



Sunfish Tuesdays will serve as the genesis, with the kickoff taking place on Tuesday, April 15. If you don't want to race on Tuesdays, that is ok. Come anyway, rig a Sunfish, and sail. Sailing is open to everyone to enjoy and we are so fortunate that the CRSA Sunfish are available. It is nice to have others around to share ideas and solve problems. We strive to give CRSA members opportunities across the board.

Following the Tuesday night kickoff is the First Splash Sunfish Regatta, which will take place on Saturday,

April 19. We are happy to help you prepare on the 15th. Remember, nobody begins as an expert and the first big accomplishment is to cross the starting line. Learning to go around a course and progressing to actually finish is the next step. Recognize that in the end (and most importantly), you are racing yourself, establishing your own baseline for comparison, grappling with your own skill and will to achieve. Sailing has a long history. Join us as we make more of it.



Boating, Edouard Manet French, 1874, Source: The Met Collection (Open Access Image), <https://www.metmuseum.org/art/collection>

Let's Go Sailing For Women By Women

Let's Go Sailing, For Women, By Women, aims to be a 'go to' environment for women interested in learning, sharing and enjoying the sport of sailing. We actively discuss and demonstrate relevant and helpful sailing information and experiences with each other. We have 18 events planned for 2025. If you're interested, please check the website (caverunsailing.org) or email Liz.Harris.Consulting@gmail.com to get on the listserv.



Let's Go Sailing thank you lunch for the men who helped us hoist, launch, and transport the Sunfish for our summer 2024 Let's Go Sailing activities

R/C Sailing Fleet

Are you feeling a little bummed out because winter is here and your sailing days are over until the birds announce the arrival of spring? Or are you just bored as you find yourself spending most of your time indoors watching football, basketball, or reruns of lousy TV shows?

Well, I offer you an alternative! Why not spend your time rigging an R/C sailboat and join us in May for our R/C racing series? You can purchase a Dragon Force 65 sailboat at radiosailing.net for \$315.00. This includes both A rig (fractional rig) and A+ rig (full rig) sails, transmitter and everything needed to sail the boat. You also get the benefit of our knowledge (based on many previous mistakes and successes) to assist you in the set-up process.

If you are interested, contact Bill Jones at (859) 421-4247 or kywmjones@gmail.com



CRSA member Tom Duffin and his Dragon Force 65

Beginning Sailing

It may be cold and snowy outside, but spring will be here before we know it! What better time to think about sailing! If you are new to Cave Run Sailing Club or you have always wanted to learn to sail, a great starting place is the Beginning Sailing Class.

We meet for two fun evenings in Lexington to cover topics such as boat parts and rigging, how the sails work, sailing knots, and "talking like a sailor", to name just a few. We then move to Cave Run Lake for a water day, putting into practice what you learned, with experienced skippers to guide and instruct you.

Spring registration is now open. Class dates are Tuesday, April 22nd and Thursday, April 24th, 7-9 pm. Water day is Saturday, April 26th on the lake.

Cost for the class is \$35 per person, which includes your book. Membership in the Club is also required (\$100 per family). Registration for both can be done on the website at caverunsailing.org.

If you have questions or need further information, please contact Beverly Hale at beginningsailing@caverunsailing.org.

Sewing Seeds at Jacobson Park -Starting in July

Youth sailing is about legacy. The link between Cave Run sailors and the youth sailors is passion. Sailing isn't only about boats. It's about friendship, it's about passion, and it's about power and working together as a team. They're all values that humans need in life, and if you don't have them, boats won't work for you. The best way to predict the future is to create it!

That's why Cave Run Sailing is determined to give youngsters a taste of the wind and water early on in life. These training days will give our younger sailors an introduction to the basics of sailing and bigger skills in life.

We plan to challenge our students to be safe on the water and have fun with others in the process. This is just the beginning of a very long way to go! And with passion, what a journey!

Location: Jacobson Park, Lexington, KY, Close to the paddle boat launch and shelter 1

Projected schedule (weather may change these dates)

Tuesday, 7/08/2025, 6-8 pm

Saturday, 7/12/2025, 1-4 pm

Tuesday, 7/15/2025, 6-8 pm

Saturday, 7/19/2025, 1-4 pm

Tuesday, 7/22/2025, 6-8 pm

Saturday, 7/26/2025, 1-4 pm (Skills and Pirate Fun Day)

Sign up on our website at caverunsailing.org

\$65 per child (plus \$35 student or \$100 family membership)

More details on the website (caverunsailing.org)!!

Questions? Chuck at emrich@aol.com or 859-270-2199



River or Pond Scene: a Sailboat and Dinghy with Figures on the Near Bank, Thomas Rowlandson British, 1784-88, Source: The Met Collection (Open Access Image), <https://www.metmuseum.org/art/collection>

Youth Sailing Needs Your Help!

Please consider giving and volunteering!!!

If we are to grow and serve more children, we need a budget to add boats, trailers, repairs, and equipment. We need to offer more scholarships to youth from families who do not have money for summertime activities. 100% of gifts go to our mission (no salaries or marketing expenses) and are now tax deductible (check with your accountant).

One simple way to give is to use the Kroger Community Rewards Program:

1. Visit <https://www.kroger.com>.
2. Login to your Kroger account. If you don't have a Kroger account, you will need to create one. New users will need to create an account which requires some basic information, a valid email address, and a registered Kroger rewards card to link to our organization. If you do not yet have a Kroger rewards card, you can get one at any Kroger customer service desk.
3. Once logged into your Kroger account, click your name in the upper right corner and select 'My Account' from the drop down menu.
4. Select 'Community Rewards' in the lefthand menu.
5. Choose (or change) the organization. You can search by name (Cave Run Youth Sailing Academy) or number (JA573).
6. Click Enroll.

Now when you shop at Kroger the Cave Run Youth Sailing Academy will get a donation. We thank you!



2024 Youth Sailing Benefit Regatta

Saturday, May 18

SUPPORTING THE CRSA YOUTH SAILING ACADEMY



CAVE RUN SAILING ASSOCIATION

<https://www.caverunsailing.org>

Commodore Sponsor: Sutherland & Associates

Lunch Sponsor:  GRATZ PARK PRIVATE WEALTH

Opti Sponsors:

- Stokley's Marine
- William & Charlotte Lubawy
- Steve & Diana Morris
- John & Judith Shropshire

Location Sponsors:

- Bank of the Bluegrass
- Mel & Abby Burch
- Dan's Boat Repair

New Sail Sponsors:

- Brad & Donna Leslie
- Lee & Molly Sutherland

Sign for the Trailer:

- Norman Williams

Sponsor a Child:

- Eastern KY Correctional Complex
- Terry Clark
- Chuck Emrich
- Jim & Sue Ellen McFarlane
- Fred & Charmaine Pfister
- Creame & Nancy Wilson

Materials Sponsors:

- Stokeley's Marine
- Craig Breil
- William & Beverly Hale
- Sam Moher
- Geoff Spencer

A huge Thank You To our Sponsors!!

2024 Sailing Retrospective

We are firmly entrenched in winter and thus far it has been snowy and cold. Though a few of us may be intrepid souls and hit the lake with raised sails despite the frigid conditions, many of us are self-relegated to our easy chair and fireplace to bask in our remembrances of 2024's sailing exploits and our sailing plans for 2025. To facilitate and perhaps keep winter's depressive doldrums at bay, share in the joy of fellow CRSA members in this pictorial montage.



Brad Leslie: Great Dismal Swamp Canal, ICW Alternate Route in Virginia

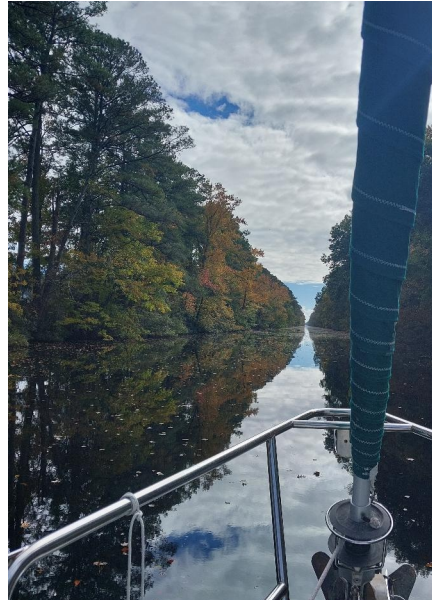

Brad Leslie: Great Dismal Swamp, ICW Alternate Route in Virginia



Brad Leslie: Albemarle Sound, ICW, North Carolina

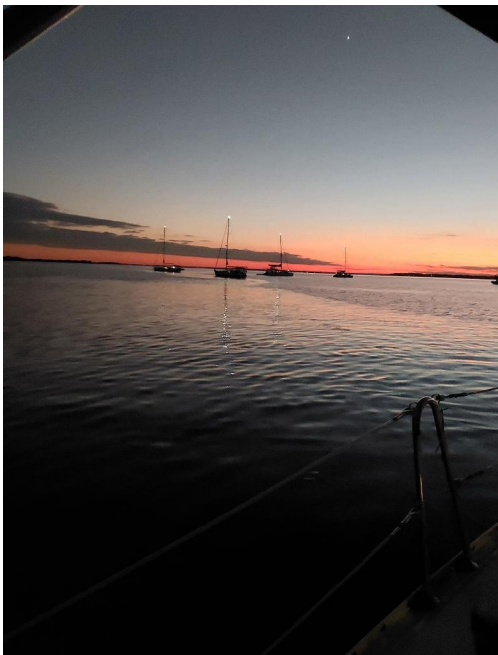

Brad Leslie: Anchorage at Cumberland Island National Seashore, Georgia



Brad Leslie: Elizabeth River, Norfolk, US Navy Yard. CVN #69 Dwight D. Eisenhower



*Molly Sutherland, Sally Shafer, Charmaine Pfister:
Cave Run, 2024*



*Fred Pfister, Chuck Emrich, Jay Shropshire:
US Virgin Islands, January 2025*



Charmaine Pfister & Boomer: Cave Run, 2024



*Charmaine Pfister: Penobscot
Bay, Maine, August 2024*



*Sally Shafer & Molly Sutherland:
Penobscot Bay, Maine, August 2024*



*Molly Sutherland: Penobscot Bay,
Maine, August 2024*



Fred Pfister: Cave Run, September 2024



Fred Pfister and Boomer: Cave Run, April 2024



Sailing US Virgin Islands, 2025



Charmaine Pfister: US Virgin Islands, 2025





Charmaine Pfister



From left to right: Sally Shafer, Molly Sutherland, Debbie Salyers, Charmaine Pfister, Hannah Kovash.



Passing off of the Storm, John Frederick Kensett American, 1872, Source: The Met Collection (Open Access Image), <https://www.metmuseum.org/art/collection>

That's My Boat

Sailors love to share tales of glory, advice and mentoring, and descriptions of their beloved boats. Most of us being shorebound for the winter and clamoring for anything sailing-related, this newsletter edition will feature two episodes of That's My Boat.

Dave Leddy

I guess I should call this article "That's My Boats" and throw them all in here, but the instruction was to keep it simple, so this will be on my current project boat, a 1995 Hunter 26, the Fellowship. This boat has been on Cave Run Lake through several owners, the most recent being Jim Dinger, so some of you are no doubt familiar with it.

It came to me back in 2022, and the most notable equipment I have added are new sails from North Sails (the ones that came with it were stolen right out of the boat on the mooring ball) and a lazy-jack sail bag combo from Doyle Sails. I have it out this winter and hope to do some work on refinishing interior woodwork and some exterior gelcoat repairs. The old Tohatsu motor has gotten ugly but runs like a champ. I should paint it; we'll see.



Fellowship

I hope to use this boat as a family cruiser, and vow to use it more this year than in the past, but the summer is filling up fast! I have used the Hunter in a couple of down-the-lake races but prefer my smaller boat for racing.



New sail bag with lazy-jack

I came to sailing through family, my Gandpa Roy in particular, who, long before my time, built a cabin on Wanaksink Lake in Upstate New York. I was the luckiest kid to grow up there in the summers, and the cottage is still in the family, shared between my brothers and sisters. Grandpa Roy was a great experimenter with sailboats and always had a 15- to 18-foot dinghy of some sort, and in 1964 he bought the first of our Sunfish, a boat I could soon sail on my own at 11 years old. He also had at that time a K-Boat, which was a 16 ft. fractional sloop rig with very wide decking to keep the water out of the cockpit through very extreme heeling. Those were the boats I grew up on.

I bought a Hobie 16 with a friend in 1978 and we sailed on Cave Run Lake, eventually storing it at Hook's into the early 80's. That boat went to stay in NY in the mid 80's, and in 2017 I brought another boat to Cave Run, a Precision 185 (18ft.). That boat is stored at Hook's and I generally use it in the club buoy races. I also have several sailboards that we sail on Florida camping vacations.



Early shakedown with new sails, grandson Mason



Hobie 16, son Daniel, cottage at Wanaksink Lake (Photo 2024)



2005 Precision 185 (Photo 2017)



1971 Sunfish (new sail and rudder), granddaughter Hadley. (Photo 2022)



Fanatic Snake with about 7.5M sail. (photo about 2009)

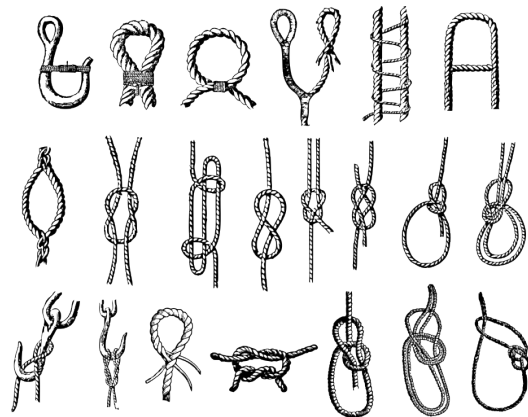

Our Sailing Journey: Jim & Nicole Moan

I've been sailing for over 40 years now, but my love for the water started during my early teenage years in New Jersey. My dad and I were looking for a way to connect, so we took a sailing class together at the local river. That class sparked something special for both of us. Not long after, we bought and restored an old 14-foot Penguin sailboat. The time we spent fixing it up together—sanding, painting, and learning how to rig the boat—created memories I'll always cherish.

Sailing has been part of my life ever since those early days. Over the years, I've owned and sailed a number of boats, each one adding its own unique chapter to my story. There were challenging moments, like the weekend sailing and camping trip with the Georgia Tech sailing club when a major storm hit while we were spending the night on one of the small islands. Then there were perfect days, like the ones I spent trailering my Precision 16 down to the Gulf of Mexico,

enjoying the clear skies and beautiful waters. Whether rough or calm, each experience holds a special place in my heart, and I can look back fondly on all of them.



When I met Nicole, she joined me in this passion. Together, we bought a Catalina 25 that we renamed "Slow Motion" and sailed it on Lake Lanier in Georgia. We spent countless days on the water, sometimes with family and friends and sometimes just the two of us. Sailing became our shared hobby, and we enjoyed not only the time spent sailing but also the time spent working on the boat together. We spent a couple years refurbishing "Slow Motion." We refinished the cockpit and replaced the sails. Nicole put her sewing skills to work to replace the covers, while I cleaned, sanded, and refinished the rudder. We replaced all of the interior cushions and bedding. Nicole began decorating it immediately, sewing pillows and hanging a new curtain at the head. I installed a new solar panel and wired in a new electric stove and safety timer, so that Nicole and I could enjoy fresh coffee in the early mornings hanging out at the boat.

In 2024, Nicole and I began a new chapter when we moved from Georgia to Lexington, Kentucky. Eager to find a local sailing community, we joined the Cave Run Sailing Association, where we were fortunate to meet Tony. We sold our 1984 Catalina 25 on Lake Lanier and purchased a new-to-us well cared for Catalina 25 1989 from Tony -

“Into the Mystic.” It was a perfect fit!

“Into the Mystic” is a fixed keel 25-foot sailboat with an 8-foot beam and a draft of 4 feet. The fixed keel provides excellent stability, ensuring that our friends who visit feel secure. Powered by a 9.9hp outboard motor, it handles well for getting in and out of her slip at Scotts Creek Marina. There are some nice upgrades on this boat compared to our previous one. The halyard on “Into the Mystic” is run to the cockpit, so Nicole does not have to navigate up to the mast to raise and lower the main. The outboard motor mount is also spring loading, which makes getting the motor into and out of the water much easier. The head has been removed and we use a portable toilet to keep maintenance easy.



These days, Nicole and I are casual day sailors, enjoying the beauty of Cave Run Lake. While we still enjoy tinkering with minor upgrades, most of our time is spent relaxing on the water, appreciating the quiet moments and the joy that sailing brings. Sailing has been a lifelong passion for me, and it's been even more rewarding to share it with Nicole. We are actively planning trips to the Florida-Georgia coast and to the

Caribbean later this year, where we plan to spend time sailing and enjoying the change of pace and scenery that the ocean waters bring.

Whether it's the calm of a leisurely sail, the satisfaction of a small boat project, or the camaraderie of the sailing community, the water has a way of bringing people together. We're grateful for the memories we've made and the ones still to come. If you see us out on the lake, wave or stop by—we'd love to share stories and swap a few sailing tips. Until then, we'll be out there, chasing the wind and enjoying the ride.







First Splash Regatta, April 19, 2025 Cave Run Sailing Association

Venue: Jacobson Park, Lexington Kentucky.

General: Regatta for Sunfish on a lake where gasoline engines are not permitted. Local Sunfish can be used but need to be reserved so we know how many to bring.

Rules: The Regatta shall be governed by the racing rules of sailing (25-29) and the class rules of the Sunfish except as altered by the sailing instructions.

Entry eligibility: The event is open to skippers of Sunfish who register before the skippers meeting. Sunfish, CRSA, or other club and or Sailing Association membership is recommended but not required.

Registration: \$25, individual or \$45, family. We plan for a light breakfast and late meal. Please try to pre-register on the website. A final registration/waiver signature at the event will be required to participate.

Schedule: Saturday, April 19, 2025

Early arrival: 9:00-9:30am

Registration and rigging: 9:00-10:15am including light breakfast/coffee

Skippers meeting: 10:15-10:30am

Warning signal: Race 1 is at 11:15am. Two-seven (or possibly more) races as determined by the Race Committee (vote on more races at 3:00 pm. Majority rules). Target time to be off the water is 3:30pm but may vary if more races are agreed to (see above)

After Race: 3:45-5:00pm, festivities food and socializing. Awards will be presented at 4:20 pm or before

Scoring and awards: Boats will be scored using the low point system. One race will constitute a regatta. If six or more races sailed, one throw out. Five-minute starts with flags/horn The top three will receive recognition. The top youth under 16 years old will be recognized.

Contact:

Website: Caverunsailing.org
Chuck Emrich: 859 270 2199 emrich@aol.com
Louis Trost: 859 893-6774 jonitrost@gmail.com

2025 ASA Certification Courses

On behalf of myself and our active American Sailing Association (ASA) Certified Instructors Brad Leslie, Jon Ware, Luke Adams, Molly Sutherland, Cliff Hynniman, and Jim Dinger, I welcome you to the 2025 instructional season. We already have students registering for courses this year, so if this is your year to start your sailing certifications or advance to the next level, it's time to think about submitting your registration (<https://www.caverunsailing.org/asa-classes/>) and starting to study the ASA book for your course.

The Association now has two Catalina 22 keelboats for the ASA 101 course instruction, and after successful completion of the course you can reserve either boat for a \$100 donation to the Cave Run Youth Sailing Academy.

If your goal is to attain the ASA 104 Bareboat Cruising certification this year, please drop me an email at ASAsailing@caverunsailing.org as soon as you can (preferably before you register), so I can alert Brad and get him thinking about a trip to the Chesapeake to conduct the course.

Congrats to all who completed ASA courses last year, 27 in all, I hope you will progress in your sailing certifications again this year!

You can find information on the ASA courses on our webpage at ASA Classes – Cave Run Sailing Association (<https://www.caverunsailing.org/asa-classes/>). For details on what is involved with each course you can drill down to the detailed course information from ASA by clicking on the course title (ASA 101, ASA 103, etc.).

Fair Winds,
David Leddy



Evening Glow at Jungai (Jungai sekishō), from the series Eight Views of the Ryūkyū Islands (Ryūkyū hakkei), Katsushika Hokusai Japanese, ca. 1832, Source: The Met Collection (Open Access Image), <https://www.metmuseum.org/art/collection>

The Librarian's Bookshelf

Winter roared in dumping snow across much of Kentucky and embracing us with bone-biting temperatures. Though it has warmed a bit as of today (January 26), it is easy to anticipate the return of cold, snow, and ice. Fret not, though. Spring will soon be here. Until we hear its marching feet, why not engage in some armchair sailing, cosying up with a good book or movie. Below are a few that might just offer solace and inspiration:

Tinkerbelle by Robert Manry

The charming, true-to-life tale of a *Cleveland Plain Dealer* employee who restored and sailed a 13.5' sloop (Old Town Whitecap made by the Old Town Canoe Company of Old Town, ME) from the Falmouth, MA to Falmouth, UK.

Des Pawson's Knot Craft & Rope Mats by Des Pawson

A wonderful collection of nautical knotwork projects to keep your fingers busy and nimble. Many projects make great gifts.

Maiden Voyage by Tania Aebi

A gripping true story about Tania Aebi's journey to circumnavigate the world in her Taylor 26 (Canadian version of the Contessa 26). Share her ups and downs as this troubled youth finds friendship, maturity, and maybe even love on the high seas.

Swallows and Amazons by Arthur Ransome

The classic children's tale (part of a twelve-book series) about four brothers and sisters who spend a summer puttering about the Lake District in the summer of 1929. Intrigue and adventure await.

Second Wind: A Sunfish Sailor, an Island, and the Voyage That Brought a Family Together by Nathaniel Philbrick

Join Nathaniel in his journey to reclaim lost glory and re-establish his sense of self in the world and in his family. Great depictions of cold-weather Sunfish sailing in and around Cape Cod. This book is a real charmer and a fast read.

Maidentrip (2013, Not Rated, 1h 22m)

The only movie in the list, this film is pure joy. Join Laura Dekker who, at 14, wanted to become the youngest person so solo circumnavigate. Was she successful? You'll have to watch the film to find out.

Your local library is a great place to explore these and other titles. If your library doesn't have it on their shelf, ask them to get it through Interlibrary Loan. Also check out your library's digital holdings through services such as Overdrive (Libby) and hoopla. You'll be amazed at what you can find.

Finally, many libraries subscribe to *SAIL Magazine* (and others) either in print or digitally.

CRSA Cookbook

Gather your favorite recipes!

One of our workgroup members will be contacting you soon to gather the best of the best recipes of our club.

This is going to be a team effort! We may be coming back to you and asking for you to help test recipes.

Our goal is to have the cookbook available for club members this fall.



2025 Race Calendar

- 4/26 Buoy Race #1
- 5/10 Buoy Race #2
- 5/31 Buoy Race #3
- 6/21 Summer Solstice - Down the Lake Race
- 7/19 Buoy Race #4
- 8/9 Buoy Race #5
- 8/23 Buoy Race #6
- 9/6 Buoy Race #7
- 9/20 Buoy Race #8

Call for help: Your assistance is graciously requested. In order to make the races a success, CRSA needs volunteers to help run or serve on the race committee for the races. It's not difficult and is a great benefit to the club and the quality of our races. Help with any of these races would be greatly appreciated. Contact CRSA Rear Commodore Ben Askren at RearCommodore@caverunsailing.org for more information or to volunteer.



DP818236 *Armed Four-Master Putting Out to Sea from The Sailing Vessels, Frans Huys Netherlandish, After Pieter Bruegel the Elder Netherlandish, Publisher Hieronymus Cock Netherlandish, ca. 1555-56, Source: The Met Collection (Open Access Image), <https://www.metmuseum.org/art/collection>*

Guess the Sailor

The first person to guess the sailor depicted (and the action being taken) in the image will win a leather key fob donated by Al Lawton!



This issue's sailor is well-known for his daring exploits on his extended journey. The image portrays one of the said feats. Image courtesy of the Metropolitan Museum of Art Open Access collection. Send responses to Mark Adler at mainsheet@caverunsailing.org. Level up your cool points by identifying at least two other triumphs enjoyed by this incredibly famous sailor. Triple your cool points by identifying the poor soul being dispatched in this picture.



Pellegrino Tibaldi inv. e dip.

Domenico M. Pratta del.

Bartolomeo Crivellini int.

*Dormi pur, Polifemo, e al sonno chiudi
L'ampia, insuta palpebra;
Tendonti insidie i Greci accorti, e crudi.*

*Già il fiero Ulisse col troncone ardente
L'occhio ti dannò ad immortal tenebra.
Mira or se sei possente.*

Classified Ads

As a benefit of membership, CRSA members may list sailing-related classified ads free of charge. Restrictions apply:

- We reserve the right to edit, revise, or to decline any classified advertisement. Cave Run Sailing Association (caverunsailing.org) will not be held liable for any damages arising out of errors or omissions.
- Accepted ads will be run in one edition of The MainSHEET. Members may resubmit for subsequent newsletters.
- Pictures will generally not be posted with an ad.
- CRSA assumes no responsibility for any ad and/or the accuracy of its representations. Rather, individuals who post and reply to ads are solely responsible for their actions.
- Submit all ad request to Mark Adler at mainsheet@caverunsailing.org.

Free to a good home:

Set of cushions for a C&C 25, a little dirty but very usable. Also salon cushions for a Hunter 23.

Contact: Brad at Brad.s.leslie@gmail.com or Steve at smorrispbs@aol.com

Beach Vacation Rentals by Liz

- Montauk, past the Hamptons, N.Y.
- Isle of Palms, S.C.
- Destin, FL**
- Naples, FL**

**10% off list price for CRSA Members

e-mail Liz.Harris.Consulting@gmail.com for links to property websites

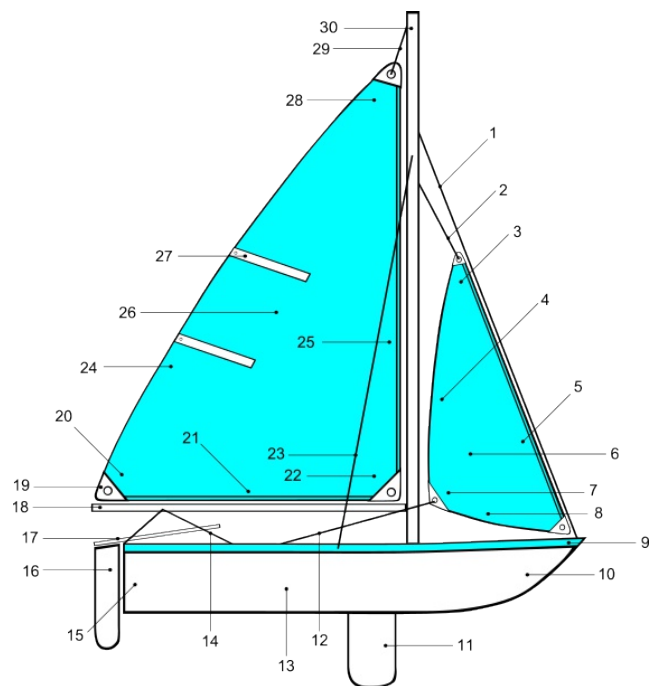
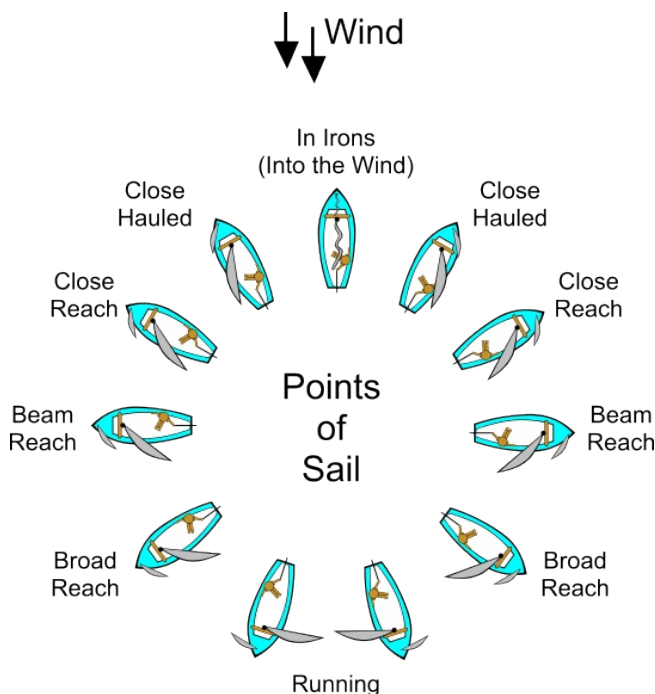



Cave Run Sailing Association
PO Box 256
Lexington, KY 40588
<https://www.caverunsailing.org>
859-810-CRSA

The MainSHEET is published 6 times per year and distributed to Cave Run Sailing Association members through email.

The Cave Run Sailing Association is an **all volunteer, non-profit organization** dedicated to the Spirit of Sailing with goals of:

- Promoting both leisure and race sailing
- Conducting sailing education classes
- Providing a forum for good will and social activities among those interested in sailing
- Participating in charitable and community service activities

Membership information can be obtained from Fred Pfister at Membership@caverunsailing.org.

The MainSHEET is edited by Mark Adler. Please contact Mark for article ideas and/or suggestions at Mainsheet@caverunsailing.org.

Special thanks to all those who contribute photos and information for this publication.

Commodore	Graeme Wilson	Commodore@caverunsailing.org
Vice Commodore	Susan McLaughlin	Vice-Commodore@caverunsailing.org
Rear Commodore	Ben Askren	RearCommodore@caverunsailing.org
Treasurer	Michael Jones	Treasurer@caverunsailing.org
Secretary	Nicole Brocato	Secretary@caverunsailing.org
ASA Sailing	David Leddy	ASAsailing@caverunsailing.org
Cruise Director	Merritt Wade	Cruisedirector@caverunsailing.org
Harbor Master	Brad Leslie	Harbormaster@caverunsailing.org
Membership	Fred Pfister	Membership@caverunsailing.org
Newsletter	Mark Adler	Mainsheet@caverunsailing.org
Social Director	Rose Perkins	Socialdirector@caverunsailing.org
Webmaster	Sam Moher	Webmaster@caverunsailing.org
Youth Sailing	Chuck & Kelly Emrich	Youthsailing@caverunsailing.org
Past Commodore	Molly Sutherland	Pastcommodore@caverunsailing.org